

# OWNER'S MANUAL



## Diversity Wireless System for Vocalist and Music Instruments

# ***Table of Contents***

---

<b>System Components.....</b>	<b>1</b>
<b>Receiver Features.....</b>	<b>2</b>
<b>Transmitter Features.....</b>	<b>4</b>
<b>System Setup.....</b>	<b>9</b>
<b>Specifications.....</b>	<b>11</b>

Thank you for choosing our wireless system, In order to obtain the best efficiency from the system, you are recommended to read this instruction manual carefully.

# ***System Components***

---

## **All systems include**

True diversity receiver  
6.35mm audio cable  
2\* BNC antennas  
Power adaptor  
User guide  
Warranty card

## **Transmitter (anyone below is selectable)**

Wireless handheld transmitter  
Wireless body-pack transmitter  
Wireless plug-on transmitter  
Wireless electric guitar transmitter  
Saxophone, harmonica, flute, accordion, clarinet, acoustic guitar,  
violin, viola, double bass, erhu, etc.

## **System Features**

UHF 600-937MHz frequency range (region dependant)  
True diversity for maximum range and dropout protection  
PLL Synthesized circuit  
Pre-set 100 (10\*10) selectable frequencies (bandwidth dependant)  
IR sync downloading the frequency from receiver  
LCD display shows status of frequency, AF and RF signal etc  
EIA standard 1/2U rack-mountable metal chassis  
Up to 300 feet(100m) line-of-sight operating range  
Designed for vocalist and musical instrument applications

# Receiver Features

---

## Front Panel

1. Power switch

Tap to turn on, tap to turn off, blue light up when receiver turns on

2. LCD display

The 63mm\*22mm high resolution LCD display shows the group, channel, frequency, antenna status, AF & RF level and IR set.

3. IR (Infrared) port

Send IR signal to transmitter for synchronization

4. UP button

Adjust the frequency, channel, group incrementally

5. SET button

Menu control to set group, channel, frequency, IR Synchron.

6. DOWN button

Adjust the frequency, channel, group degressively

7. Volume control

Adjust the volume level, volume knob encircled by blue light

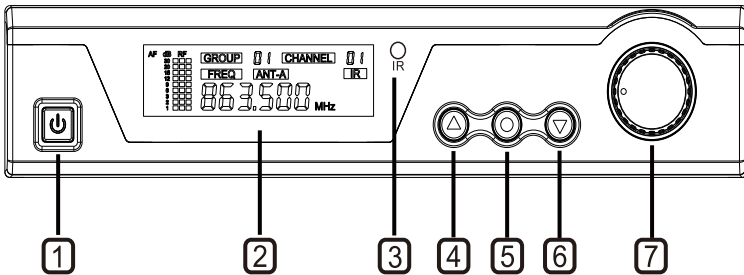

# Receiver Features

---

## Back Panel

8. Power supply jack (DC12-18V / 500mA)

Connecting the power supply unit

9. 6.35mm (1/4") unbalanced output jack

Connect the unbalanced input, e.g. of mixer or amplifier

10. Balanced XLR output jack

Connect the unbalanced input, e.g. of mixer or amplifier

11. BNC antennas sockets

Connect the high gain antennas

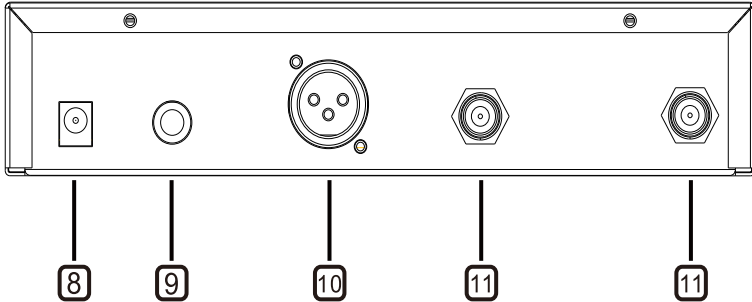

# Transmitter Features

---

## Handheld Transmitter Option 2

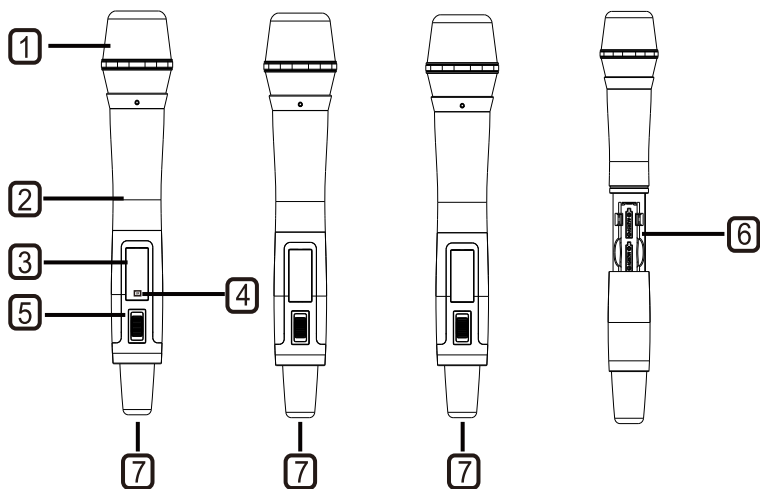

1. Microphone head  
Cartridge inside
2. Metal pipe (Aluminum alloy)  
Anodize any different colors, never fade.
3. Backlit LCD  
Display group, channel, frequency and battery life
4. IR infrared port  
Receiver infrared beam to synchronize frequencies, hold the transmitter with its IR port facing direct to receiver's IR port in a distance between 5-20cm  
**Note:** When using multiple systems, only one transmitter IR port should be expose at a time.
5. ON/OFF and Mute switch  
Push up the switch to turn on, Mute at the mid position
6. Battery compartment  
To replace batteries, unscrew the bottom pipe part counter-clockwise, make sure to put the battery in the right polar directions
7. Caps-on

# Transmitter Features

## Body-pack Transmitter

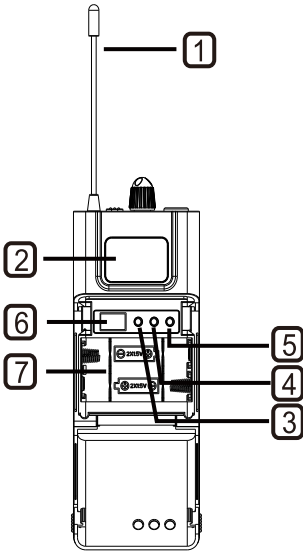

1. Antenna  
1/4 wave length wire type antenna, it should be fully extended during normal operations
2. Backlit LCD  
Display frequency and battery life, if the battery symbol blinks, the battery need to be replaced immediately
3. UP button  
Adjust the frequency, incrementally
4. SET button  
Menu control to set frequency
5. DOWN button  
Adjust the frequency degressively
6. IR infrared port  
Receiver infrared beam to synchronize frequencies, hold the transmitter with its IR port facing direct to receiver's IR port in a distance between 5-20cm.  
**Note:** When using multiple systems, only one transmitter IR port should be expose at a time.

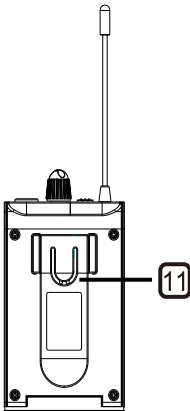

7. Battery compartment  
To replace batteries, slightly press the marked positions on left and right side of the cover and open forward, make sure to put the battery in the right polar directions.
8. Input  
3-pin mini XLR input for supplier microphone, guitar cable or other musical instrument microphones (saxophone, violin, viola, cello, acoustic guitar etc)
9. Volume control  
Clockwise to enlarge, counter-clockwise to reduce
10. Light touch power switch  
Tap to turn on, long press (2 seconds) to turn off.

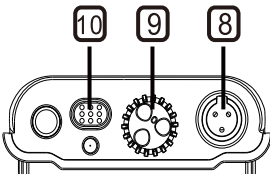

11. Belt-clip  
Clip to the belt or guitar strap

# Transmitter Features

## Plug-on Transmitter

1. Audio input: Female XLR Plug(With Lock)

2. 48V phantom power indicator

When the phantom power switch is turned on, the 48V blue indicator lights up.

3. PO power indicator

When the power is turned on, the PO red indicator lights up.

4. IR sync window

Pair the receiver's frequency by infrared SYNC

5. Power button

Long-press over 1 sec to turn on and off

6. 48V phantom power switch

When the switch is on the right side, 48V phantom power is ON. At the moment, the plug-on transmitter can connect and operate with condenser microphones.

When the switch is on the left side, 48V phantom power is OFF, At the moment, the plug-on transmitter can connect and operate with dynamic microphones.

7. Low battery Button

When battery life is low, the LO red indicator starts flickering. It should be charged immediately.

8. Charge indicator

When it is charging, the indicator appears bright green, when it's fully charged, the indicator appears off or very light color

9. MINI-USB charger jacket

Use 5V power adapter only

10. Antenna Jacket

The antenna is detachable. Be sure to rotate the antenna when using it.

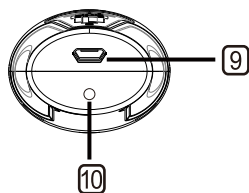
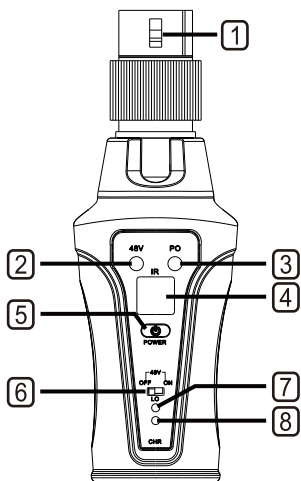

# Transmitter Features

## Electric guitar electronic musical instrument

### Guitar Straight plug/Angled plug

#### 1. 1/4" inch plug

Insert this standard 1/4" plug into your electric musical instrument. Note that the angling of the plug can be configured for Fender and Gibson electric guitar and bass. The angled plug can be configured for all 6.35mm end mount-jacks electric musical instrument e.g. electric violin, electric saxophone etc.

#### 2. BATT/PO

Power and battery LED, this blue LED remains lighting as long as the transmitter has power; the blue LED flashing means the battery need to be replaced immediately.

#### 3. Mute

Move the switch to left side to mute the microphone

#### 4. Light touch power switch

Tap to turn on, long press (2 seconds) to turn off.

#### 5. Antenna

1/4 wave length wire type antenna, it should be fully extended during normal operations

#### 6. IR infrared port

Receiver infrared beam to synchronize frequencies, hold the transmitter with its IR port facing direct to receiver's IR port in a distance between 5-20cm.

#### 7. Battery compartment

Insert a standard AA alkaline battery here, make sure to put the battery in the right polar directions.

#### 8. Battery cover

Pull back gently on this cover at the ribbing and pry upwards to remove

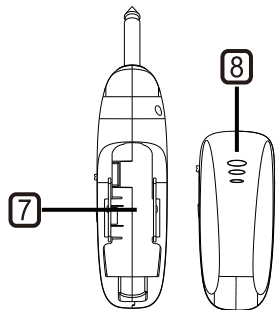
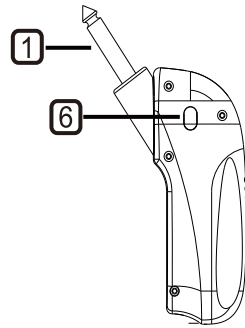
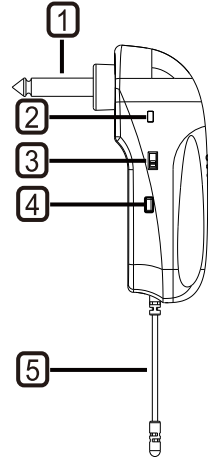

# Transmitter Features

## Saxophone/Horn Transmitter

### 1. Input mic

Unidirectional Condenser microphone pick up of Saxophone / horn's sound

### 2. Gooseneck pipe

Adjustable at any Angle

### 3. Spring clip

Clamp the spring clip on the saxophone's bell mouth to pick up the sound, and the spring clip is equipped with a rubber protective cover to avoid damage to the instrument.

### 4. BATT/PO

Power and battery LED, this blue LED remains lighting as long as the transmitter has power; the blue LED flashing means the battery need to be replaced immediately.

### 5. Mute

Move the switch to left side to mute the microphone

### 6. Light touch power switch

Tap to turn on, long press (2 seconds) to turn off.

### 7. Antenna

1/4 wave length wire type antenna, it should be fully extended during normal operations

### 8. IR infrared port

Receiver infrared beam to synchronize frequencies, hold the transmitter with its IR port facing direct to receiver's IR port in a distance between 5-20cm.

### 9. Battery compartment

Insert a standard AA alkaline battery here, make sure to put the battery in the right polar directions.

### 10. Battery cover

Pull back gently on this cover at the ribbing and pry upwards to remove

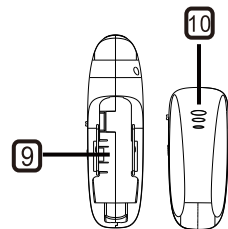
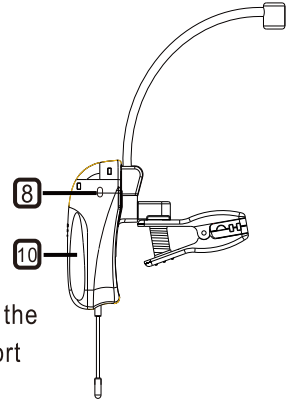
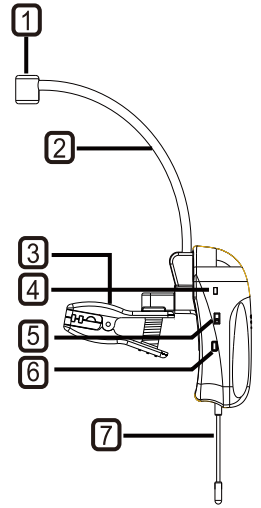

# System Setup

1. Connect the included AC power supply to the rear of the receiver and turn on the receiver.

## 2. Standard Display

The standard display shows the preselected group, channel

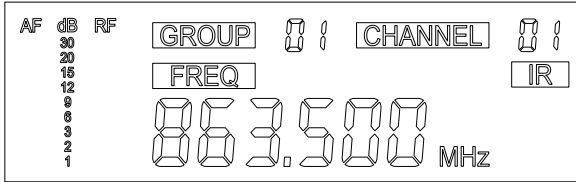

### Group

Push the SET button and hold for 1 second, the GROUP blink, Push the up and down buttons to set the desired group (01-10), Press SET again to confirm. The display will return to standard after a short period of time of non-activity automatically.

**NOTE:** Each group 01-10 consists of 10 channels, each corresponding to a specific frequency.

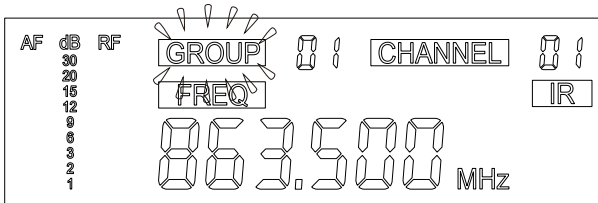

### Channel

After the step of setting group, press the SET again, the CHANNEL blink. Push the up and down buttons to set the desired channel (01-10), Press SET again to confirm. The display will return to standard after a short period of time of non-activity automatically.

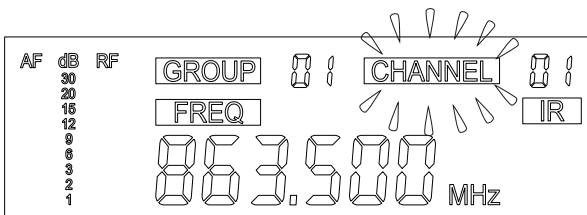

# System Setup

## IR Synch

After the step of setting channel, press the SET again, the IR blink (picture 1).

Push the SET button and hold for 1 second, the receiver start to send the infrared signals (picture 2), then put the transmitter (handheld, body-pack or musical instrument) IR port close to the receiver's IR port, the transmitter has to be synchronized to the same frequency (group and channel) before using.

**NOTE:** Hold the transmitter with its IR port facing direct to receiver's IR port in a distance between 5-20cm. After a successful sync, the display RF signal and ANT-A shows up (picture 3)

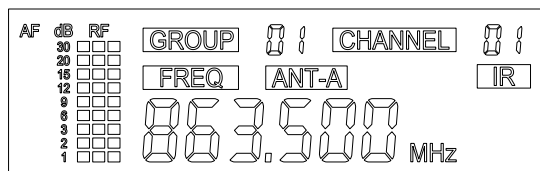
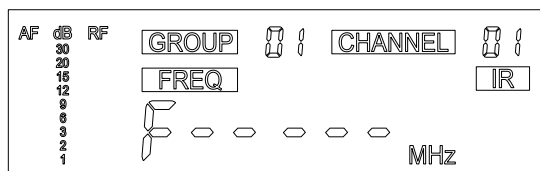
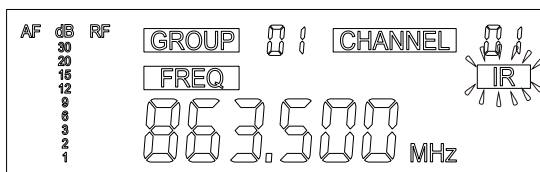

# Specifications

---

## Receiver

Frequency Preparation	PLL Synthesized Control
Frequency Range	600-937MHz (Region dependant)
Frequency Type	F3E
Modulation Type	FM
Channels:	100(10x10)
Oscillation System	VCO
Type of reception	True Diversity
Receive Sensitivity	-110dBm (sinad $\geq$ 30dB)
Frequency Response	60Hz-17KHz+/-3dB
S/N Ratio	$\geq$ 105dB (-60dBm)
T.H.D	<0.5% at 1KHz
Dynamic Range	> 100dB
Operating Temperature	-10-+50 $\square$
Display	Backlit LCD (63mm*22mm)
Audio Output	1*Balanced XLR Socket 1*6.35mm Jack
Antenna:	2*BNC
Power Supply	DC12V-18V/500mA
Dimensions( L*W*H):	210*170*44mm

## Handheld Transmitter

Frequency Preparation	PLL Synthesized Control
Frequency Range	600-937MHz (Region dependant)
Frequency Deviation	$\pm$ 48KHz
Microphone Type	Dynamic
Polar Pattern	Cardioid
RF Output Power	10mW
Controls	ON/MUTE/OFF
Indicators	Backlit LCD
Interface	Infrared
Power Supply	2*AA battery
Operating Voltage	3V
Operating time	10h (depending on batteries)
Dimensions	265mm

# Specifications

---

## Body-pack Transmitter

Frequency Preparation	PLL Synthesized Control
Frequency Range	600-937MHz(Region dependant)
Frequency Deviation	±48KHz
Input	3 pin mini-XLR
RF Output Power	10mW
Controls	Power ON//OFF, Volume, SET frequency
Indicators	LED (PO), LCD(BATT, frequency)
Interface	Infrared
Antenna:	1/4 wave Length Wire Type
Power Supply	2*AA battery
Operating Voltage	3V
Operating time:	10h (depending on batteries)
Dimensions( L*W*H)	110*63*21mm

## Electronic Musical Instrument Transmitter

### Guitar Straight plug/Angled plug

Frequency Preparation	PLL Synthesized Control
Frequency Range	600-937MHz (Region dependant)
Frequency Deviation	±48KHz
RF Output Power	10mW
Controls	ON/OFF, Mute
Indicators	LED(PO/BATT)
Interface	Infrared
Antenna:	1/4 wave Length Wire Type
Power Supply	1*AA battery
Operating Voltage	1.2-1.5V
Operating time:	10h (depending on batteries)
Dimensions	120*54*28mm(straight plug) 90*71*28mm(angled plug)

# Specifications

---

## Saxophone Transmitter

Frequency Preparation	PLL Synthesized Control
Frequency Range	600-937MHz (Region dependant)
Frequency Deviation	±48KHz
Microphone Type	Condenser
Polar pattern:	Ultra-cardioid
Cartridge size:	Φ 14*5.0mm
Sensitivity:	- 47dB±2dB
RF Output Power	10mW
Controls	ON/OFF, Mute
Indicators	LED(PO/BATT)
Interface	Infrared
Antenna:	1/4 wave Length Wire Type
Power Supply	1*AA battery
Operating Voltage	1.2-1.5V
Operating time:	10h (depending on batteries)
Dimensions	165*66*28mm

## Plug-on Transmitter

Frequency Preparation	PLL Synthesized Control
Frequency Range	600-937MHz(Region dependant)
Frequency Deviation	±48KHz
Input	Female XLR(with lock)
RF Output Power	10mW
Controls	Power ON/OFF, 48VON/OFF
Indicators	LED (PO/48V/LO/CHR)
Interface	Infrared
Antenna:	1/4 wave Length Wire Type
Power Supply	Lithium battery
Operating Voltage	3.7V
Operating time:	5h (depending on batteries)
Dimensions( L*W*H)	180*20*10mm



The specification won't do any further notice for the improvement

Actual product will not be as pictured